



ISO 13851

Dispositivi di comando a due mani

ISO 13851:2019

Safety of machinery

Two-hand control devices

**Principles for design and
selection**

Preview ISO 13851:2019

Foreword

ISO (the International Organization for Standardization) is a worldwide federation of national standards bodies (ISO member bodies). The work of preparing International Standards is normally carried out through ISO technical committees. Each member body interested in a subject for which a technical committee has been established has the right to be represented on that committee. International organizations, governmental and non-governmental, in liaison with ISO, also take part in the work. ISO collaborates closely with the International Electrotechnical Commission (IEC) on all matters of electrotechnical standardization.

The procedures used to develop this document and those intended for its further maintenance are described in the ISO/IEC Directives, Part 1. In particular, the different approval criteria needed for the different types of ISO documents should be noted. This document was drafted in accordance with the editorial rules of the ISO/IEC Directives, Part 2 (see www.iso.org/directives).

Attention is drawn to the possibility that some of the elements of this document may be the subject of patent rights. ISO shall not be held responsible for identifying any or all such patent rights. Details of any patent rights identified during the development of the document will be in the Introduction and/or on the ISO list of patent declarations received (see www.iso.org/patents).

Any trade name used in this document is information given for the convenience of users and does not constitute an endorsement.

For an explanation of the voluntary nature of standards, the meaning of ISO specific terms and expressions related to conformity assessment, as well as information about ISO's adherence to the World Trade Organization (WTO) principles in the Technical Barriers to Trade (TBT) see www.iso.org/iso/foreword.html.

This document was prepared by Technical Committee ISO/TC 199, *Safety of machinery*.

This second edition cancels and replaces the first edition ([ISO 13851:2002](http://www.iso.org/iso/13851:2002)), which has been technically revised.

The main change compared to the previous edition is the adaptation of the safety-related parts of the control system from the categories to the Performance Level (PL) (according to [ISO 13849-1](http://www.iso.org/iso/13849-1)) or SIL with the allocated HTF (according to IEC 62061).

Any feedback or questions on this document should be directed to the user's national standards body. A complete listing of these bodies can be found at www.iso.org/members.html.

Introduction

The structure of safety standards in the field of machinery is as follows:

- a) **type-A standards** (basic safety standards) giving basic concepts, principles for design and general aspects that can be applied to all machinery;
- b) **type-B standards** (generic safety standards) dealing with one safety aspect or one or more type(s) of safeguard that can be used across a wide range of machinery:
 - — type-B1 standards on particular safety aspects (e.g. safety distances, surface temperature, noise);
 - — type-B2 standards on safeguards (e.g. two-hand controls, interlocking devices, pressure sensitive devices, guards);
- c) **type-C standards** (machine safety standards) dealing with detailed safety requirements for a particular machine or group of machines.

This document is a type-B2 standard as stated in [ISO 12100](#).

This document is of relevance, in particular, for the following stakeholder groups representing the market players with regard to machinery safety:

- — machine manufacturers (small, medium and large enterprises);
- — health and safety bodies (regulators, accident prevention organizations, market surveillance etc.).

Others can be affected by the level of machinery safety achieved with the means of the document by the above-mentioned stakeholder groups:

- — machine users/employers (small, medium and large enterprises);
- — machine users/employees (e.g. trade unions, organizations for people with special needs);
- — service providers, e.g. for maintenance (small, medium and large enterprises);
- — consumers (in case of machinery intended for use by consumers).

The above-mentioned stakeholder groups have been given the possibility to participate at the drafting process of this document.

In addition, this document is intended for standardization bodies elaborating type-C standards.

The requirements of this document can be supplemented or modified by a type-C standard.

For machines that are covered by the scope of a type-C standard and have been designed and built according to the requirements of that standard, the requirements of that type-C standard take precedence.

A two-hand control device (THCD) is a protective device. It provides protection for the operator against reaching danger zones during hazardous situations by locating the control actuating devices in a specific position and distance from the danger zone(s).

The selection of a THCD as an appropriate safety device depends upon the risk assessment made by designers, standard makers and others in accordance with [ISO 12100](#).

The definition of a THCD is given in [3.1](#) and takes precedence over the definition given in [ISO 12100](#).

In some arrangements, enabling devices (see [ISO 12100](#)) and/or hold-to-run devices (see [ISO 12100](#)) may comply with the definition of a THCD in this document. Additionally, some special control devices — such as some crane controls — require the use of two hands and can comply with the definition of a THCD in this document.

1 Scope

This document specifies the safety requirements of a two-hand control device (THCD) and the dependency of the output signal from the actuation by hand of the control actuating devices.

This document describes the main characteristics of THCDs for the achievement of safety and sets out combinations of functional characteristics for three types. It does not apply to devices intended to be used as enabling devices, as hold-to-run devices or as special control devices.

This document does not specify with which machines THCDs shall be used. It also does not specify which types of two-hand-control device shall be used for a specific application. Moreover, while guidance is given, it does not specify the required distance between the THCD and the danger zone (see [8.8](#)).

This document provides requirements for design and guidance on the selection (based on a risk assessment) of THCDs including the prevention of defeat, the avoidance of faults and verification of compliance.

NOTE 1 A THCD only offers protection for the person using it.

NOTE 2 For specific machines, the suitability of a two-hand control as a suitable protective device can be defined in a type-C standard. If such a standard does not exist or is not appropriate, the risk assessment and determination of suitable protective measures is the responsibility of the manufacturer of the machine.

This document applies to all THCDs, independent of the energy used, including:

- — THCDs which are fully assembled for installation;
- — THCDs which are assembled by the machine manufacturer or integrator.
- This document is not applicable to THCDs manufactured before the date of its publication.

2 Normative references

The following documents are referred to in the text in such a way that some or all of their content constitutes requirements of this document. For dated references, only the edition cited applies. For undated references, the latest edition of the referenced document (including any amendments) applies.

- [ISO 12100:2010](#), *Safety of machinery — General principles for design — Risk assessment and risk reduction*
- [ISO 13849-1:2015](#), *Safety of machinery — Safety-related parts of control systems — Part 1: General principles for design*
- [ISO 13849-2:2012](#), *Safety of machinery — Safety-related parts of control systems — Part 2: Validation*
- [ISO 13855:2010](#), *Safety of machinery — Positioning of safeguards with respect to the approach speeds of parts of the human body*
- IEC 62061:2005+AMD1:2012+AMD2:2015, *Safety of machinery — Functional safety of safety-related electrical, electronic and programmable electronic control systems*

3 Terms and definitions

For the purposes of this document, the terms and definitions given in [ISO 12100](#) and the following apply.

ISO and IEC maintain terminological databases for use in standardization at the following addresses:

- — ISO Online browsing platform: available at <https://www.iso.org/obp>
- — IEC Electropedia: available at <http://www.electropedia.org/>

3.1

two-hand control device

THCD

device which requires simultaneous actuation by the use of both hands in order to initiate and to maintain hazardous machine functions, thus providing protective measure only for the person who actuates it

Note 1 to entry: See [Figure 1](#).

Figure 1 — Schematic representation of a THCD

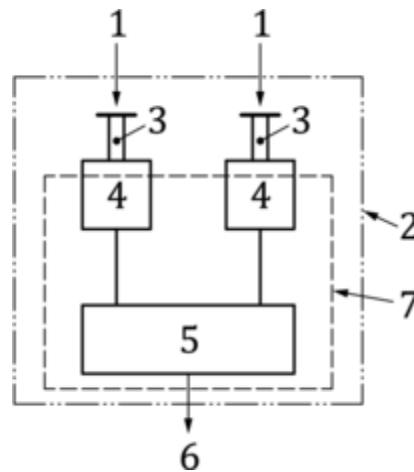

Key

1	actuation by hands	5	signal processor(s)
2	THCD	6	output signal(s)
3	control actuating devices (actuators)	7	logic unit
4	signal converter(s)		

Note 2 to entry: Inclusion of [Figure 1](#) is a modification of [ISO 12100:2010, 3.28.4](#).

3.2

input signal

externally actuated signal applied by hand to a **control actuating device** (3.3)

Note 1 to entry: See [Figure 1](#).

3.3

control actuating device

actuator

component of the **THCD** (3.1) which senses an **input signal** (3.2) from one hand and transmits it to a **signal converter** (3.6)

Note 1 to entry: See [Figure 1](#).

3.4

simultaneous actuation

continuing actuation of both **control actuating devices** (3.3) during the same time period, whatever the time lag is between the start of one **input signal** (3.2) and the start of the other

Note 1 to entry: See [Figure 2](#).

3.5

synchronous actuation

particular case of **simultaneous actuation** (3.4) within a defined time period

Note 1 to entry: See also [5.8](#).

3.6**signal converter**

component of the **THCD** (3.1) which receives an **input signal** (3.2) from a **control actuating device** (3.3) and which transmits and/or converts this signal into a form acceptable to the **signal processor** (3.7)

Note 1 to entry: See [Figure 1](#).

3.7**signal processor**

part of the **THCD** (3.1) which generates the **output signal** (3.8) as a consequence of the actuation by hands

Note 1 to entry: See [Figure 1](#).

3.8**output signal**

signal generated by the **THCD** (3.1) intended to be processed by a control system

Note 1 to entry: See [Figure 1](#).

3.9**response time**

time between the release of a **control actuating device** (3.3) and the cessation of the **output signal** (3.8)

Note 1 to entry: See also [8.8](#).

3.10**relocatable THCD**

device which can be moved and used in more than one definable position relative to the danger zone of the machine with which it is interfaced

Bibliography

- [1] EN 894-3, *Safety of machinery — Ergonomics requirements for the design of displays and control actuators — Part 3: Control actuators*
- [2] EN 894-4, *Safety of machinery — Ergonomics requirements for the design of displays and control actuators — Part 4: Location and arrangement of displays and control actuators*
- [3] IEC 60073, *Basic and safety principles for man-machine interface, marking and identification — Coding principles for indicators and actuators*
- [4] IEC 60204-1, *Safety of machinery — Electrical equipment of machines — Part 1: General requirements*
- [5] IEC 60947-5-1, *Low-voltage switchgear and controlgear — Part 5-1: Control circuit devices and switching elements — Electromechanical control circuit devices*

- [6] IEC 60947-5-2:2007+AMD1:2012, *Low-voltage switchgear and controlgear — Part 5-2: Control circuit devices and switching elements — Proximity switches*
 - [7] IEC 60947-5-3, *Low-voltage switchgear and controlgear — Part 5-3: Control circuit devices and switching elements — Requirements for proximity devices with defined behaviour under fault conditions (PDDB)*
 - [8] IEC 61310-1, *Safety of machinery — Indication, marking and actuation — Part 1: Requirements for visual, acoustic and tactile signals*
 - [9] IEC 61310-2, *Safety of machinery — Indication, marking and actuation — Part 2: Requirements for marking*
 - [10] IEC 61310-3, *Safety of machinery — Indication, marking and actuation — Part 3: Requirements for the location and operation of actuators*
 - [11] IEC 62745, *Requirements for cableless control systems of machinery*
 - [12] [ISO 9355-1](#), *Ergonomic requirements for the design of displays and control actuators — Part 1: Human interactions with displays and control actuators*
 - [13] [ISO 9355-3](#), *Ergonomic requirements for the design of displays and control actuators — Part 3: Control actuators*
 - [14] [ISO 11064-5](#), *Ergonomic design of control centres — Part 5: Displays and controls*
 - [15] [ISO 4413](#), *Hydraulic fluid power — General rules and safety requirements for systems and their components*
 - [16] [ISO 4414](#), *Pneumatic fluid power — General rules and safety requirements for systems and their components*
 - [17] [ISO/TR 14121-2](#), *Safety of machinery — Risk assessment — Part 2: Practical guidance and examples of methods*
-

Fonte: ISO